

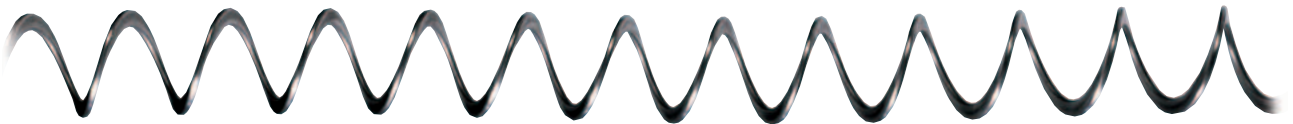

# Big Dutchman®



## **Silos and augers**

Feed storage and transport systems

# Silos – the base for hygienic feed storage

Big Dutchman offers its customers external and internal silos including accessories for hygienic feed storage:

- silos made of galvanized sheet steel

- silos made of glass-fiber reinforced plastic (GRP)
- inside silos made of Trevira fabric. You can choose the right silo of the appropriate size out of a wide range of products. All systems can

be filled pneumatically or by auger. The respective silo size depends on daily feed consumption and required storage time.

## Advantages

- high-quality galvanization of all steel parts and use of glass-fiber reinforced plastic (GRP) = long service life;
- trouble-free feed withdrawal due to optimum degree of slope in the silo funnel;
- auger box either rigid or flexible, adjustable from 0 to 45° – ensures operational safety;
- roof shape ensures use of the entire volume;
- the use of GRP silos allows simple checking on feed level due to the transparency of the material;
- high functional reliability.

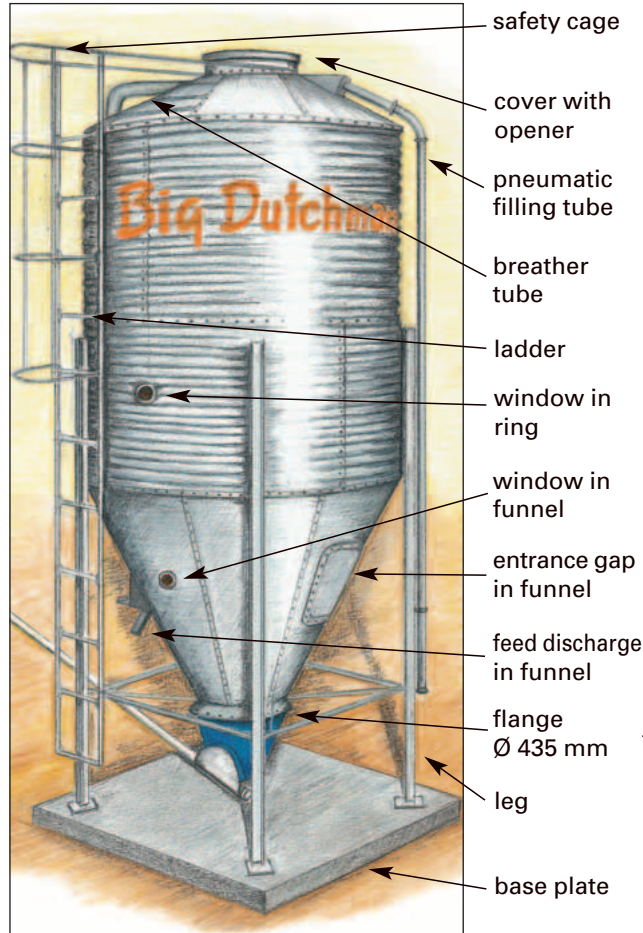

## A number of options – spirals, augers, cable and chain conveyors – are available

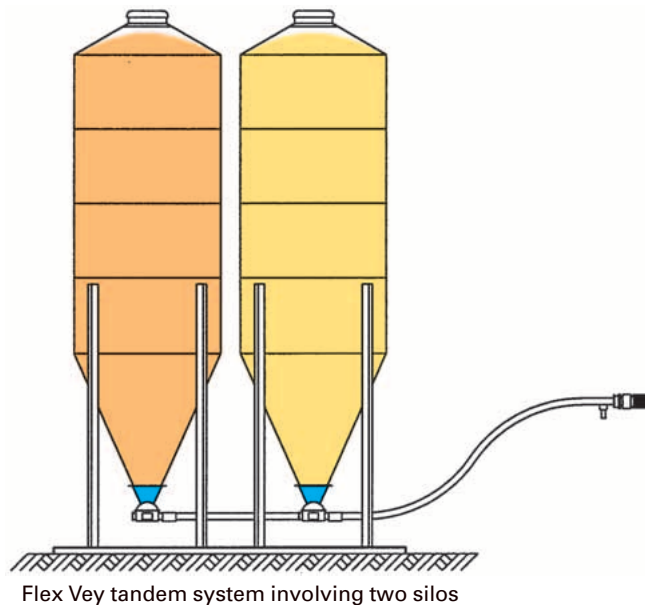
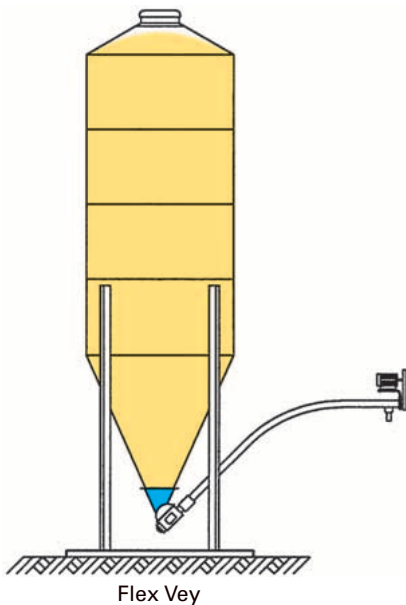

# Augers and Flex Vey for feed transport

With Big Dutchman, your feed – be it meal, pellets or crumbs – passes from the silo into the house safely and without any loss of quality. We offer augers and Flex Vey conveyor systems in a variety of sizes. For conveying capacities up to 4.5 t/h, the Flex Vey (spiral) is normally used. In case of even higher capacities or pitches up to 75° it is the auger. In exceptional circumstances, even pitches up to 90° can be carried out (max. length of auger 10 m). Which system is the right one for you depends on your individual requirements.



Feeding augers for high conveying capacities



Flex Vey conveyor spirals – simple and flexible conveying systems

- the Big Dutchman Flex Vey conveyor spiral comprises high-quality and extremely flexible spring steel;
- the feed can be transported into the house around bends of up to 90° safely, quickly and without feed separation;
- universal application for each type of house;
- for high conveying capacities;
- fast and easy assembly;
- can be driven by means of a V-belt motor or a gear motor.

## System for transporting feed from the silo into the house

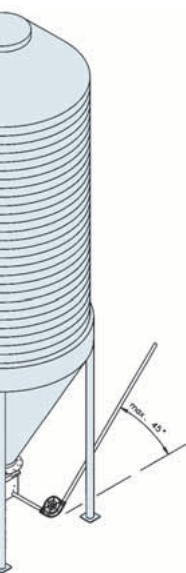

Conveyor chain (DR 850/DR 1500)

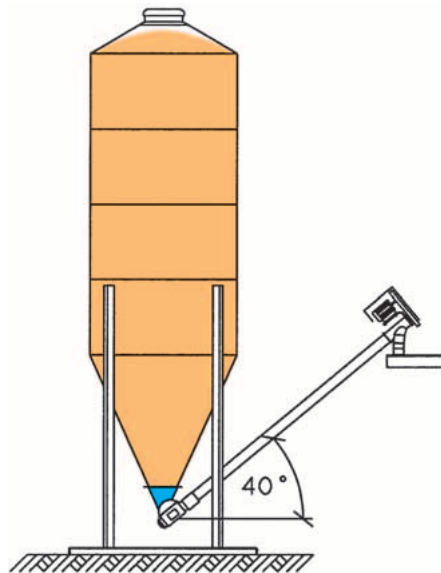

Vertical and cross conveying augers

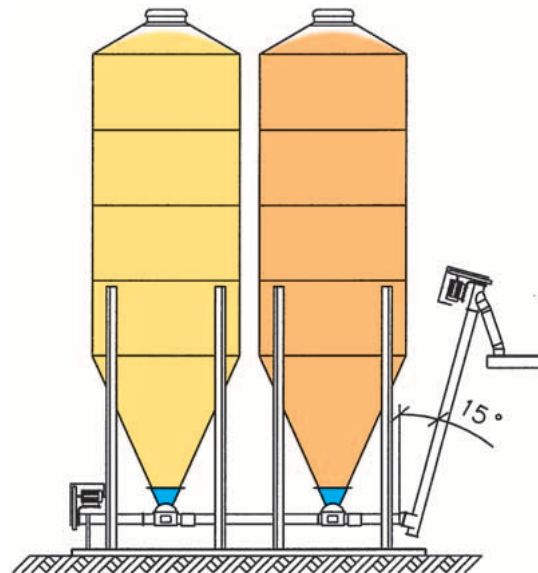

Tandem auger and forced transfer

# Technical data and planning details for silos

## 1. Galvanized sheet steel silos

Type	Code No.	Volume (m <sup>3</sup> )	Overall height (m)	Ø of the silo (m)
B-P*	25-17-9410	4,1	3,50	1,80
B-P*	25-17-9420	6,3	4,40	1,80
R-P*	25-17-6102	8,1	5,03	1,80
B-P*	25-17-9430	8,6	5,30	1,80
B-P*	25-17-9520	9,1	5,65	2,10
R-P*	25-17-6103	10,2	5,84	1,80
R-P*	25-17-6111	11,6	5,38	2,10
B-P*	25-17-9530	12,3	6,46	2,10
B-P*	25-17-9540	15,4	7,47	2,10
B-P*	25-17-9620	16,6	5,60	2,75
R-P*	25-17-6113	17,4	7,00	2,10
R-P*	25-17-6120	20,6	6,08	2,75
B-P*	25-17-9630	21,8	6,30	2,75
R-P*	25-17-6121	25,0	6,89	2,75
B-P*	25-17-9640	27,0	7,00	2,75
R-P*	25-17-6122	30,0	7,71	2,75
R-P*	25-17-6123	35,0	8,52	2,75
R-P*	25-17-6124	39,8	9,33	2,75

\* silos, not assembled, also available with mechanic filling (B-M, R-M)  
- more silo types available on request

## 2. Silos made of glass-fiber reinforced polyester

GRP silos are only offered fully fitted incl. filling and breather tube. They are available for holding from 4 to 60 m<sup>3</sup> of contents, with a height of 3.85 to 13.07 m in a great variety of types. They are corrosion-resistant and weatherproof as well as virtually maintenance-free.

## 3. Inside silos made of Trevira fabric

Inside silos consist of a Trevira bag and a steel stand. The silo bag with a 400 mm outlet has a sewn-on collar for connection to an auger box. These inside silos are available with volumes of 5.15 to 20.95 m<sup>3</sup>.

Type	Code No.	Volume (m <sup>3</sup> )	Overall height (m)
GS-1	25-30-3206	5.15	3.05
GS-A	25-30-3207	6.15	3.30
GS-B	25-30-3209	8.15	3.80
GS-C	25-30-3211	10.15	4.30
GS-D	25-30-3214	12.95	4.80
GS-E	25-30-3217	15.95	5.30
GS-F	25-30-3220	18.95	5.80
GS-G	25-30-3222	20.95	6.30

**Note:** The average weight of feed amounts to 0.65 t/m<sup>3</sup>  
Example: 8.4 m<sup>3</sup> silo x 0.65 t/m<sup>3</sup> = 5.5 t feed

# Technical data and planning details for augers

Type	S102	S150	K150	TS200
conveying capacity (horizontal)*	3 500 kg/h	15 000 kg/h	9 000 kg/h	26 000 kg/h
max. conveying length	12 m	12 m	25 m	25 m
V-belt motor **	0.75-2.2 kW	1.1-2.2 kW	1.5-2.2 kW	2.2-4 kW
motor speed	365 rpm	365 rpm	252 rpm	225 rpm
outside diameter of tube	102 mm	152 mm	- ***	- ***
material	galvanized tube	galvanized tube	varnished trough	varnished trough
wall thickness	1.5 mm	2 mm	2 mm	2 mm

\* with a bulk density of 0.65 t/m<sup>3</sup> of the material to be conveyed; the conveying capacity decreases by approx. 30 % at a pitch of 45°  
\*\* gear motor also available on request  
\*\*\* open trough, also available with galvanized cover on request

# Technical data and planning details for Flex Vey

Type	Flex Vey 75	Flex Vey 90	Flex Vey 125
conveying capacity (horizontal)*	1400 kg/h	2500 kg/h	4500 kg/h
max. conveying length	60 m	40 m	25 m
gear motor (300 rpm)	0.55/0.75 kW	0.75/1.1 kW	1.5 kW
V-belt motor (365 rpm)	0.75 kW	0.75 kW	1.1 kW
outside diameter of tube	75 mm	90 mm	125 mm
material / wall thickness	PVC **/ 3.3 mm	PVC **/ 3.5 mm	PVC / 5 mm
tube bend radius - 45°/90°	1750 mm	2550 mm	2750 mm
outside diameter of spiral	60 mm	70 mm	100 mm
pitch of spiral	60 mm ***	65 mm	70 mm

\* the conveying capacity decreases by 30 % at a pitch of 45°  
\*\* galvanized tube also available on request

\*\*\* 40 mm also available on request



# Big Dutchman.

### Germany

**Big Dutchman International GmbH**  
**Big Dutchman Pig Equipment GmbH**  
Postfach 1163 · 49360 Vechta · Germany  
Tel. +49 (0) 4447-801-0  
Fax +49 (0) 4447-801-237  
E-Mail: big@bigdutchman.de

### Asia

**BD Agriculture (Malaysia) Sdn. Bhd.**  
No. 20, Lorong Keluli 1 B,  
Kawasan Perindustrian Bukit Raja,  
Seksyen 7, 40000 Shah Alam,  
Selangor Darul Ehsan · Malaysia  
Tel. +60-3-33 61 5555 · Fax +60-3-33 42 2866  
e-mail: bdasia@bigdutchman.com

### USA

**Big Dutchman, Inc.**  
3900 John F. Donnelly Dr.  
Holland, MI 49422 · USA  
Tel. +1-616-392-5981 · Fax +1-616-392-6899  
e-mail: bigd@bigdutchmanusa.com